

SANICONDENS BEST FLAT

CONNECTIONS



BOILER



AIR
CONDITIONER



HVAC

APPLICATIONS



RESIDENTIAL



COMMERCIAL



Example of installation. Follow local plumbing codes for actual install.

The Sanicondens Best Flat is a low profile pump used to **neutralize and pump condensate from condensing boilers, HVAC systems, water heater systems, etc.** The Sanicondens Best Flat will pump condensate waste up to **15 feet in height and/or 150 feet away** from a soil stack.

- Discharges the condensate waste through a 3/8" vinyl tube. A non-return valve is included on the discharge connection provided with the system.
- Comes with provisions for a ready-to-wire connection to an external overflow switch that will shut down the appliance or alert the consumer in the event of overflow. It also includes all necessary hardware for ease of installation; 20 Ft of vinyl tubing, inlet adapter, discharge adapter.
- Discharges condensate from a condensing boiler or other condensate producing fixtures. The condensate will drain into the system via a side inlet or through a couple of inlets on top of the enclosure.
- Comes equipped with a built-in neutralizer to raise pH levels for harsh HVAC applications. Neutralizing granules come included with the condensate pump. Will neutralize condensate from appliances up to 500,000 BTU/hour input.



PUMPING DISTANCE

15 Ft



150 Ft

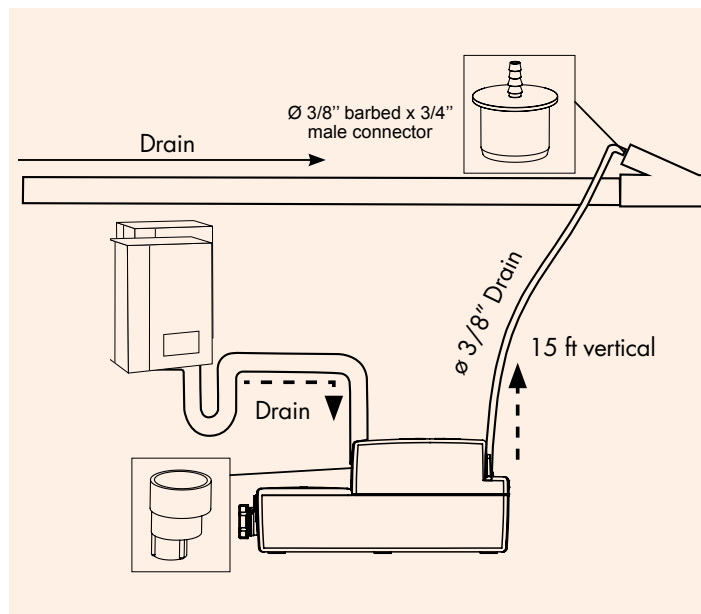

2 IN 1 CONDENSATE PUMP WITH BUILT-IN NEUTRALIZER FOR HARSH HVAC APPLICATIONS

Neutralizing agent (Part# 042) is used to **raise the pH level** from condensate being produced by condensing boilers, air conditioners, etc. The two quart capacity condensate pump comes equipped with **all the necessary hardware for easy installation.** It can be installed on top of flat surface or mounted on a wall.



**PLEASE CALL US TOLL-FREE AT
800-571-8191 (US) / 800-363-5874 (CDN)
TO PURCHASE PARTS REFERENCED BELOW**

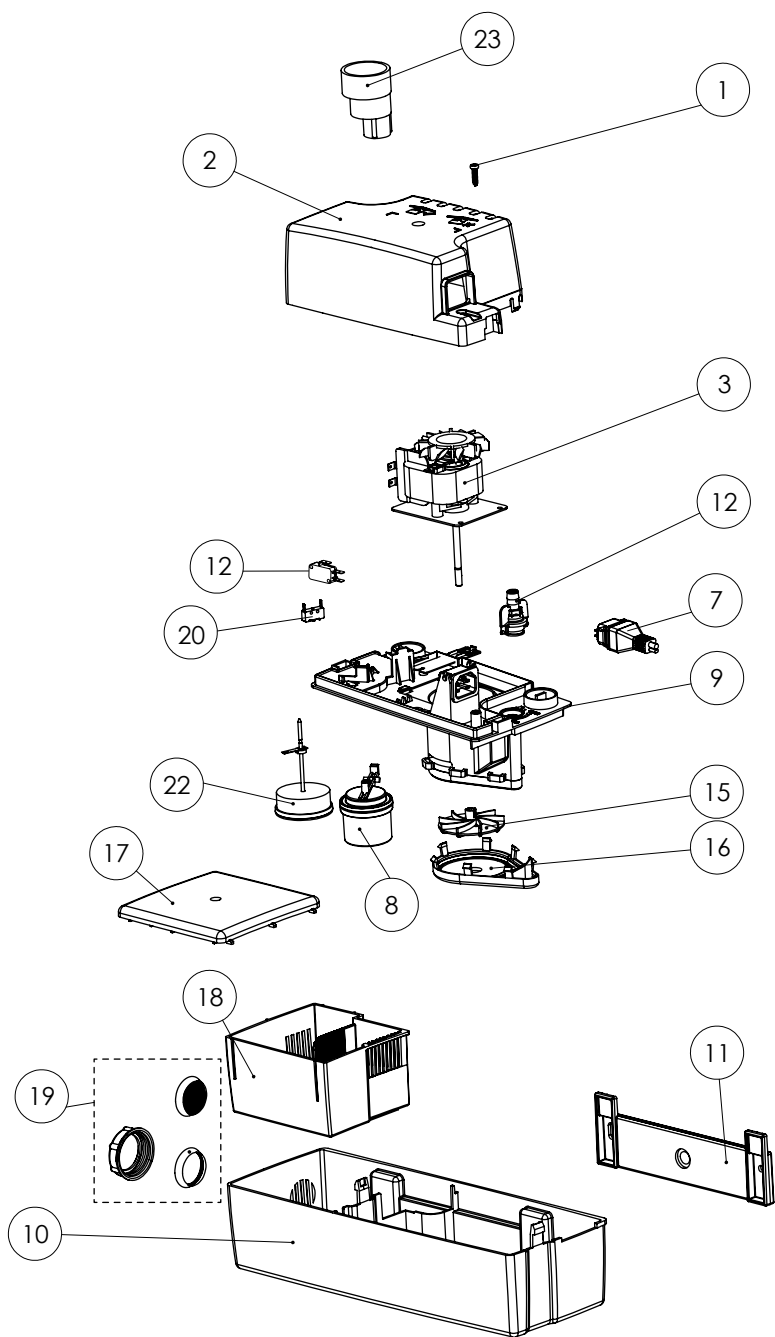

DIMENSIONAL DRAWINGS

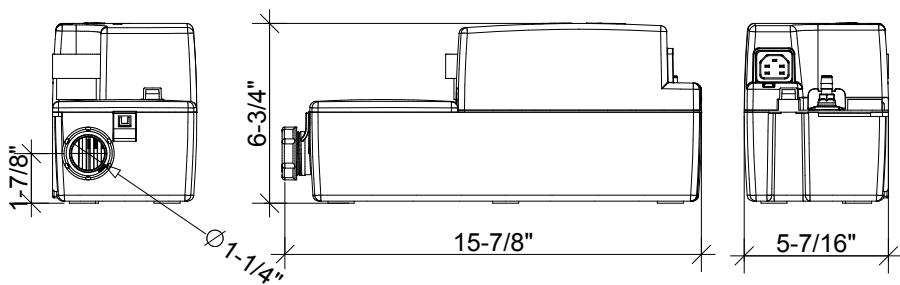

TECHNICAL SPECIFICATIONS

Pump type:

Condensate pump

Electrical:

120 V – 60 Hz / 1.5 Amps (Max)

Motor:

1/30 HP oil-filled thermally protected motor

Operating Temperature:

160°F Max

Power cord length:

61-1/2 inches

Noise level:

≤ 44 dBA (Lp) (measured at 3 ft.)

Discharge pipe diameter:

3/8"

Discharge rate at 15 ft:

30 GPH

Discharge rate at 3 ft:

86 GPH

Normal running time:

3-5 sec (Short bursts)

Capacity:

0.9 gallons / 3.4 liters

Inlets:

1" (top), 1" (side)

Method of activation:

Float/Microswitch

Weight:

12 lbs / 5.4 kg

Certifying agencies:

CSA (IPC, NSPC)

Recommended Accessories:

Neutralizing granules (Part# 042)

Connections:

Condensing boiler, HVAC systems,
air conditioners

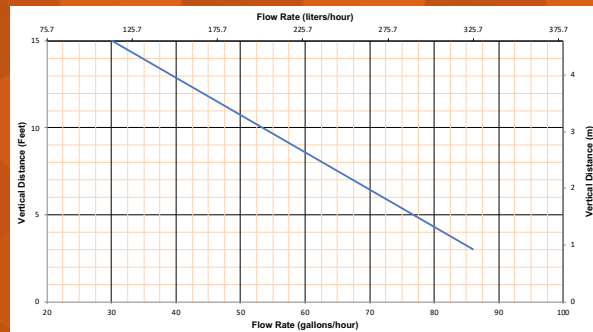

Pump away harsh condensate from any HVAC application!