

N



JAY R. SMITH MFG. CO.®
 DIVISION OF SMITH INDUSTRIES, INC.
 POST OFFICE BOX 3237
 MONTGOMERY, ALABAMA 36109-0237 (USA)
 TEL: 334-277-8520 FAX: 334-272-7396 www.jrsmith.com



MEMBER OF:

LOCATION

DRAWING NUMBER
S4240

SIZE
A

SCALE:
NONE

DATE:
2-16-70

APPROVED BY:
JM

CHECKED BY:
BH

DRAWN BY:
RK

4240 SERIES

FIGURE NUMBER

WE CAN ASSUME NO RESPONSIBILITY FOR USE OF SUPERSEDED OR VOID DATA
DIMENSIONS ARE SUBJECT TO MANUFACTURERS TOLERANCE AND CHANGE WITHOUT NOTICE

FLOOR CLEANOUTS WITH "TWIS-TO-FLOOR®" ADJUSTABLE TOPS FOR UNFINISHED AREAS

ROUND CAST IRON TOP - TRACTOR COVER

FUNCTION: Used in unfinished areas where a loose set, non-tilt tractor cover is desired. Will withstand heavy load traffic.

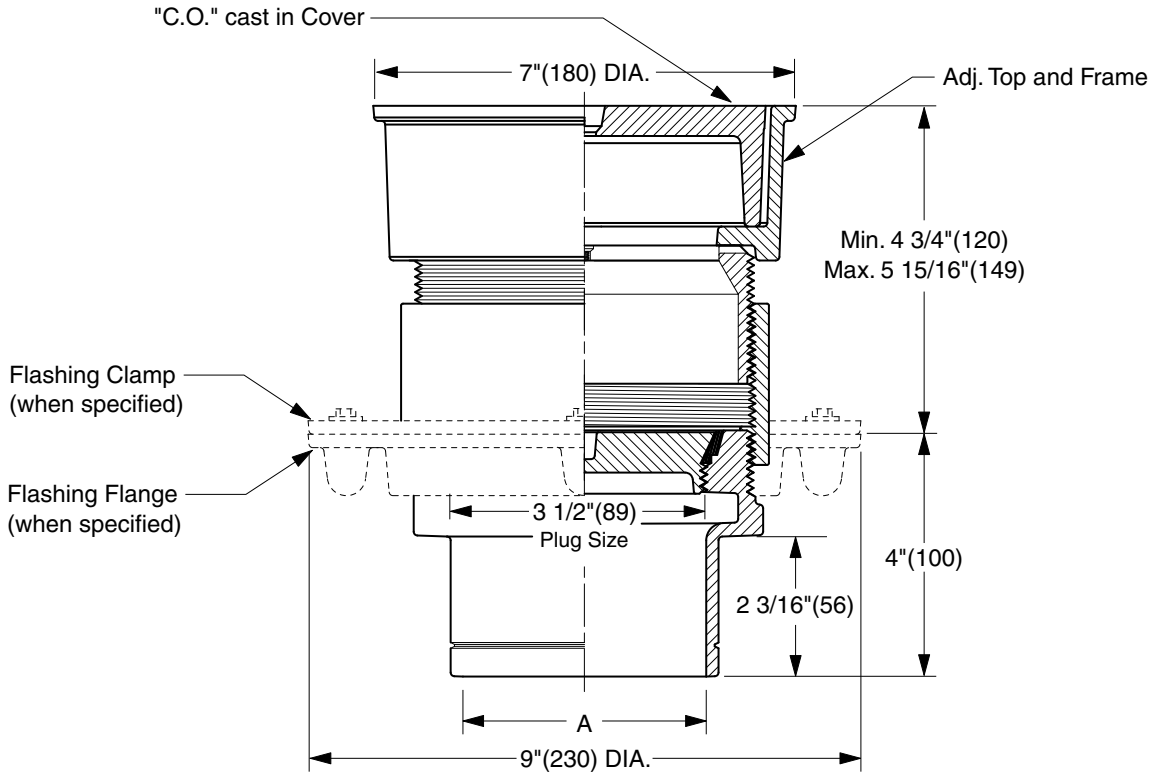

TWIS-TO-FLOOR® ADJUSTMENT

NO-HUB OUTLET

"A" (Pipe Size) = 02(50), 03(75), 04(100) or 05(125)

- Fig. 4240S.....Gasket Seal - ABS Plug
- Fig. 4241S.....Gasket Seal - Bronze Plug
- Fig. 4243S.....Taper Thread - Bronze Plug
- Fig. 4244S.....Taper Thread - ABS Plug

(Twis-to-Floor® design shown with gasketed plug.)

NOTE: Dimensions shown in parentheses are in millimeters.

REGULARLY FURNISHED:

Duco Cast Iron Cleanout with Round Adjustable Scoriated Cast Iron Top with Non-Tilt Tractor Cover. Closure Plug Type as Indicated by Figure Number Selected.

VARIATIONS:

- Center Securing Screw -CSS
- Vandal Proof Center Securing Screw -U
- Flashing Flange -F
- Flange with Flashing Clamp -F-C

OPTIONAL MATERIALS:

- Galvanized Cast Iron -G
- Ductile Iron Cover -M
- Nickel Bronze Top -NB
- Polished Bronze Top -PB

N	07/29/02	Corrected Clamp & Flange view	JJ	CL
M	05/07/01	Edited Outlet Text	JJ	CL
L	10/31/00	New design	JJ	BS
REV.	DATE	DESCRIPTION	BY	CKD. BY

WEIGHT
POUNDS

VOLUME
CUBIC FEET

FIGURE NUMBER

4240 SERIES



JAY R. SMITH MFG. CO.

DIVISION OF SMITH INDUSTRIES, INC.
 POST OFFICE BOX 3237
 MONTGOMERY, ALABAMA 36109-0237 (USA)
 TEL: 334-277-8520 FAX: 334-272-7396 www.jrsmith.com



MEMBER OF:

LOCATION

FLOOR CLEANOUTS WITH "TWIS-TO-FLOOR®" ADJUSTABLE TOPS FOR UNFINISHED AREAS

ROUND CAST IRON TOP - TRACTOR COVER

FUNCTION: Use in unfinished areas where a loose set, non-tilt tractor cover is desired. Will withstand heavy load traffic.

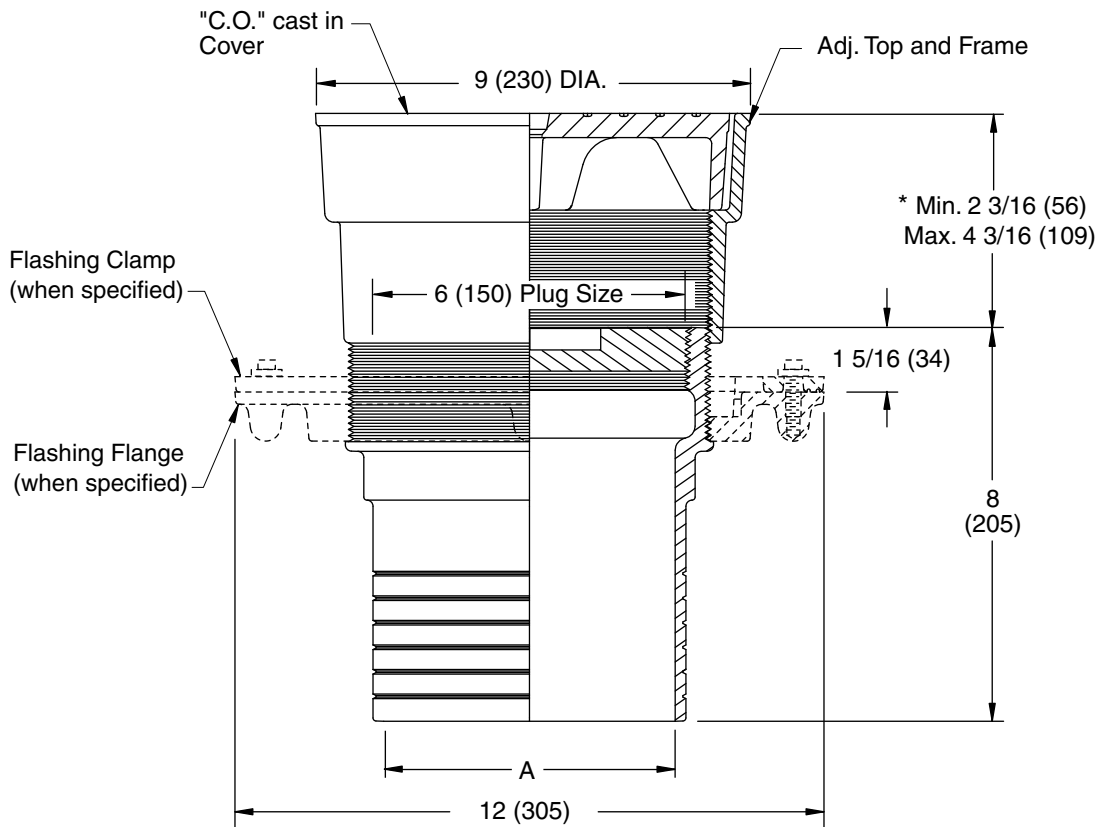

SPIGOT OUTLET ▲

"A" (Pipe Size) = 06(150) & 08(200)

▲ Sized for Service Weight and/or NO-HUB.

* When Flange-F is specified Min. 2 3/16 (56) becomes 2 11/16 (68)

"TWIS-TO-FLOOR®" ADJUSTMENT

SPIGOT OUTLET ▲

Fig. 4243S.....Taper Thread - Bronze Plug

REGULARLY FURNISHED:

Duco Cast Iron Cleanout with Taper Thread Bronze Plug and Round Adjustable Scoriated Cast Iron Top with Non-Tilt Tractor Cover.

VARIATIONS:

- Flashing Flange -F
- Flange with Flashing Clamp -F-C
- Vandal Proof Top -U
- Center Securing Screw -CSS

OPTIONAL MATERIALS:

- Galvanized Cast Iron -G
- Polished Bronze Top -PB
- Nickel Bronze Top -NB
- Ductile Iron Cover -M

NOTE: Dimensions shown in parentheses are in millimeters.

DRAWING NUMBER
S4240BS

SIZE
A

SCALE:
NONE

DATE:
5-5-06

APPROVED BY:
CEL

CHECKED BY:
CL

DRAWN BY:
RN

FIGURE NUMBER
4243

WE CAN ASSUME NO RESPONSIBILITY FOR USE OF SUPERSEDED OR VOID DATA

REV.	DATE	DESCRIPTION	BY	CKD. BY

WEIGHT POUNDS	VOLUME CUBIC FEET

FIGURE NUMBER
4243